



1. 適用範圍 / SCOPE

WH42 系列，快速熔斷器。
 WH42 series, high speed fuse.

2. 產品型號 / TYPE

例「example」：

WH42	100A	700V	① 系列號 / Series Number
↓	↓	↓	② 額定電流 / Rated Current
①	②	③	③ 額定電壓 / Rated Voltage

3. 額定電流和額定電壓 / RATED CURRENT AND RATED VOLTAGE

額定電流 / Rated Current: 5A~100A
 額定電壓 / Rated Voltage: 700V AC/DC

4. 標示 / MARKING

保險絲上需有下列標示/The fuses shall have the following marking

製造工廠的標識+系列號/ Manufacture' s Logo+ Part Number:

額定電流+額定電壓/ Rated Current (A)+ Rated Voltage(V):

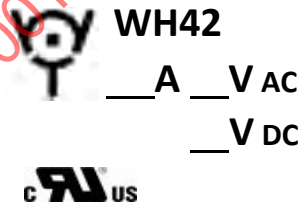

注意 / Note :

對標示的大小和位置沒有規定 / Size and position of the markings shall not be provided.

5. 外觀及形狀 / APPEARANCES AND CONFIGURATION

5-1 外觀：不應有破碎、明顯的污斑。

Appearances: There shall not be break up and any remarkable blotch.

5-2 螺栓安裝,提供其他安裝方式选择

Stud-mount, optional for other installtion

6. 工程圖和結構 / OUTLINE DRAWING AND STRUCTURE

6-1 工程圖（單位：mm） / Outline Drawing and Dimensions (Unit: mm)

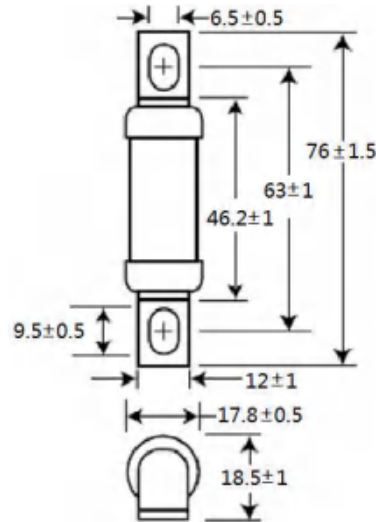
7. 電氣特性 / ELECTRICAL CHARACTERISTICS

品名 Type	料號 Ordering P/N	額定電流 Rated Current (A)	額定電壓 Rated Voltage (V)	分斷能力 Breaking Capacity (A)	I2t 值 Energy Integrals I2t (A2S)		1 倍功耗 1.0In Power loss (W)
	WH42-XXX-M6				Pre-Arcing	Clearing at 700V	
WH42	WH42-35- M6	35	700Vac	50KA	270	1800	11
	WH42-40- M6	40			400	2600	12
	WH42-50- M6	50			500	3300	13.5
	WH42-60- M6	60			730	4800	15
	WH42-70- M6	70	700Vdc		890	5700	18
	WH42-80- M6	80			960	6200	20
	WH42-90- M6	90			1200	7400	23
	WH42-100- M6	100			1400	9100	25



8. 時間電流曲線 Time-Current Curve

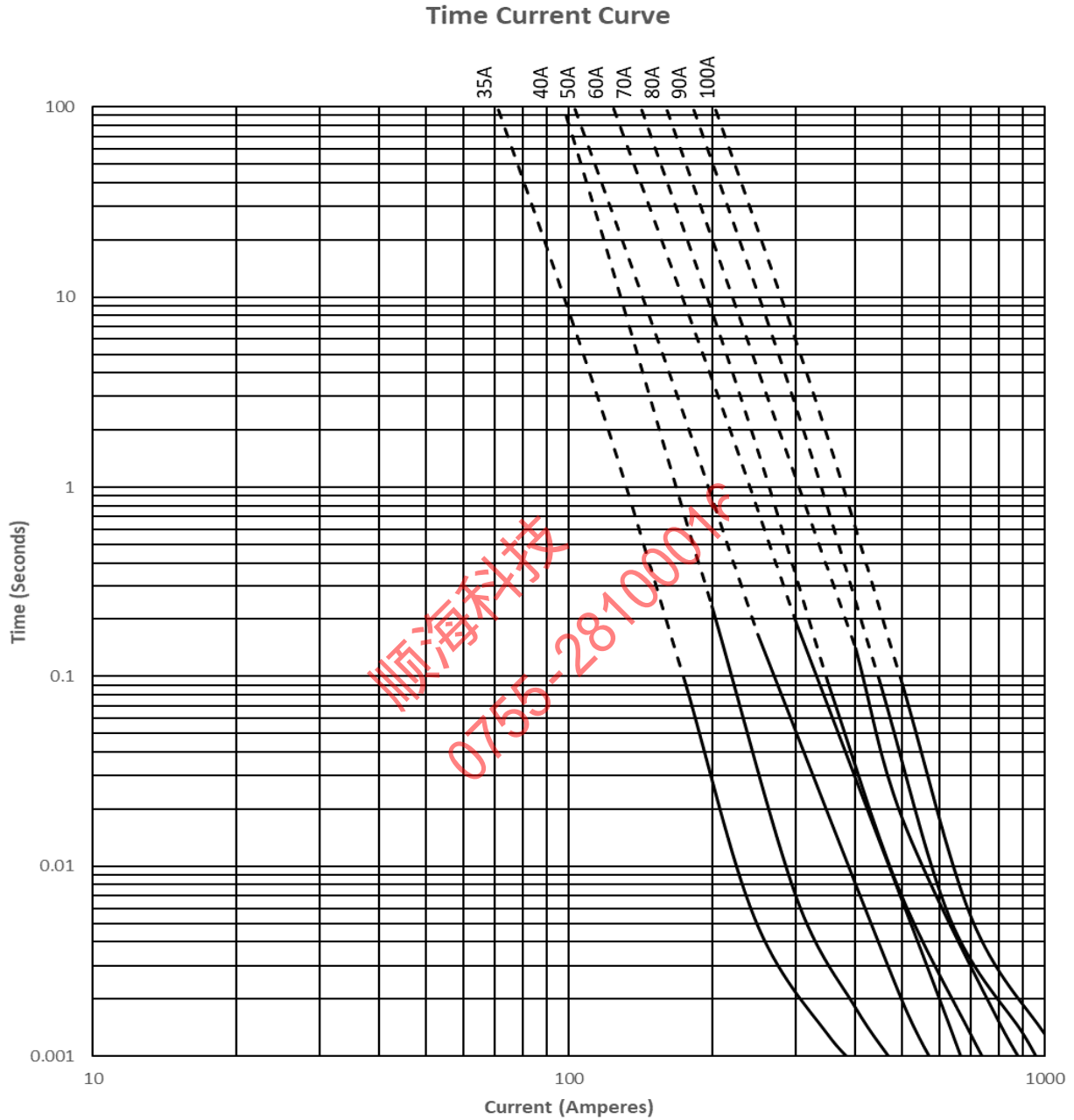

9. 環境特性 / ENVIRONMENTAL CHARACTERISTIC
9-1 操作溫度範圍: -55°C ~ 125°C / Operating Temperature: -55°C ~ 125°C

若貴司操作環境溫度超出25±5°C範圍，在選用保險絲規格時，需考慮操作環境溫度對保險絲的影響。
請參照：溫度-電流曲線圖。

When choosing the fuse's specification, if the operating environmental temperature beyond the scope from 20~30°C, you should consider the environmental temperature's affection to fuses.

Please refer : Temperature-Current curve:

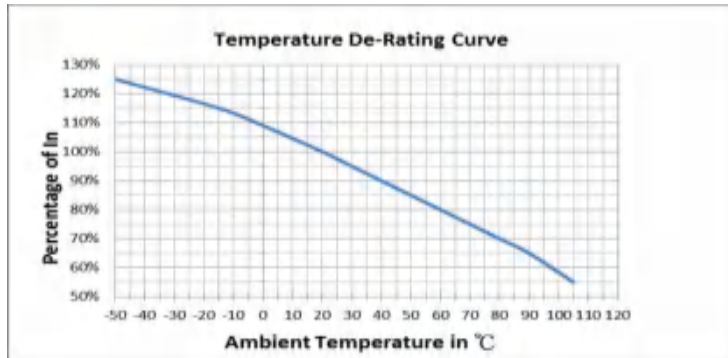
9-2 存儲條件 / Storage Conditions

在溫度+10°C ~ 60°C、相對濕度≤75%的密閉條件下可存放3年。

Under airtight in temperature+10°C ~ 60°C、relative humidity ≤75% can store 3 years.

在溫度+10°C ~ 60°C、相對濕度為95%的非露天下最多可存放30天。

Without dew in temperature+10°C ~ 60°C、relative humidity be 95% maximum value for 30days.

10. 安裝方式及條件 / INSTALLATION WAY AND PARAMETERS
10-1 螺栓安裝,提供其他安裝方式選擇

Stud-mount, optional for other installtion

11. 安全認證及編號 / STANDARDS AND APPROVALS

UR	E483392 (5A~100A JDYX2)
CUR	E483392 (5A~100A JDYX8)

12. 操做說明/Application note

12-1 熔斷器工作時容易受到周圍環境及持續通過的電流的影響，爲了延長熔斷器的使用壽命，必須確保熔斷器的負載電流小於額定電流的65%。

A fuse is easily influenced by its surrounding atmosphere and by the power of the continuous electric current passing through it. To lengthen the life span of your fuses, ensure that your target workload is

less than 65% of their rated current

12.2 當應用于直流回路保護時, 根據直流回路的實際條件, 有時必須確保熔斷器的額定電壓高于回路電壓(參考下面直流電路的調額曲線).

When using a fuse in a DC circuit, depending on the circuit condition, you may have to use a higher rated voltage fuse than the circuit voltage. (See time constant graph below)

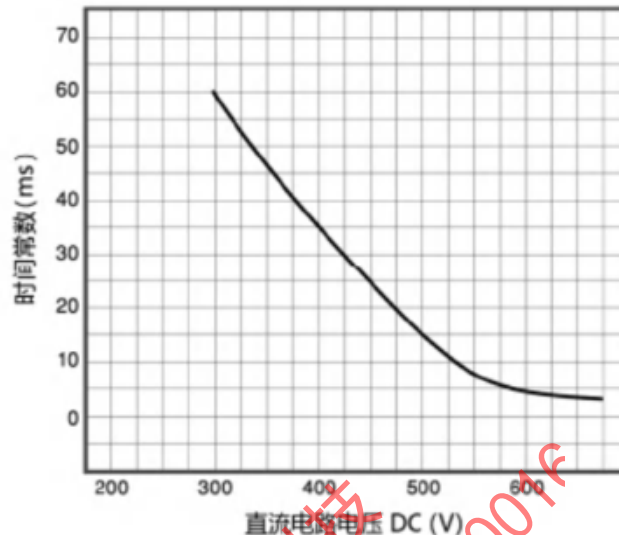

12.3 如果回路中出現低倍過載電流(落在時間-電流曲線的虛綫區域), 那麼熔斷器應該配合其他的保護裝置共同使用.

If there is a possibility of due to an over loaded current which is in dot-line zone of TCC curve, the fuse should be used in conjunction with other protectors.

12.4 當通電電流小于額定電流時, 可以通過如下修正公式得到熔斷器的實際功率損耗:
額定電流下的功率損耗 * 修正係數 α

When the applied current is lower than the rated current, you can get the value of the power loss as follow:
Power loss of rated current * Coefficient α of the applied current.

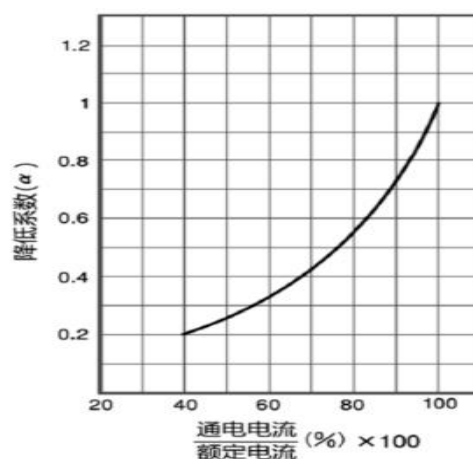

13. 包裝及數量 / Packing and Quantity

13-1 數量 / Quantity

規格 Specification	內盒 / Inner box	外箱 / Outer carton
WH42-XXX- M6	10 PCS	350 PCS

13-2 內盒 / Inner box of

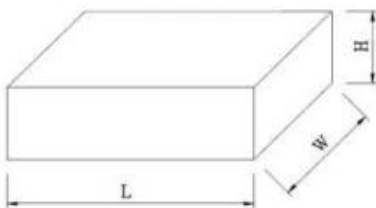

單位/Unit : mm

規格/Specification	L	W	H
WH42-XXX- M6	100±5	80±5	43±5

13-3 外箱 / Outer carton

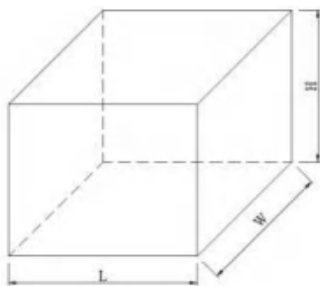

單位/Unit : mm

規格/Specification	L	W	H
WH42-XXX- M6	380±5	245±5	200±5

順海科技
 0755-28100016



14. 其他 / OTHERS

14-1 如果在使用中有超出本規格書的要求，必須經由雙方協商確認。

In the event that an impropriety is found beyond this specification, it shall be fixed by mutual agreement between the parties.

14-2 如果本規格書有不適當的情況，必須通過雙方協商並由本公司修改。

In the event that an impropriety is found in this specification, WALTER ELECTRONIC CO., LTD. shall amend it by mutual agreement between the parties.

版次	製作	確認	審核
第一版	侯愛珍	吳讓彬	Andrew